

MUV Electric Wheelbarrow

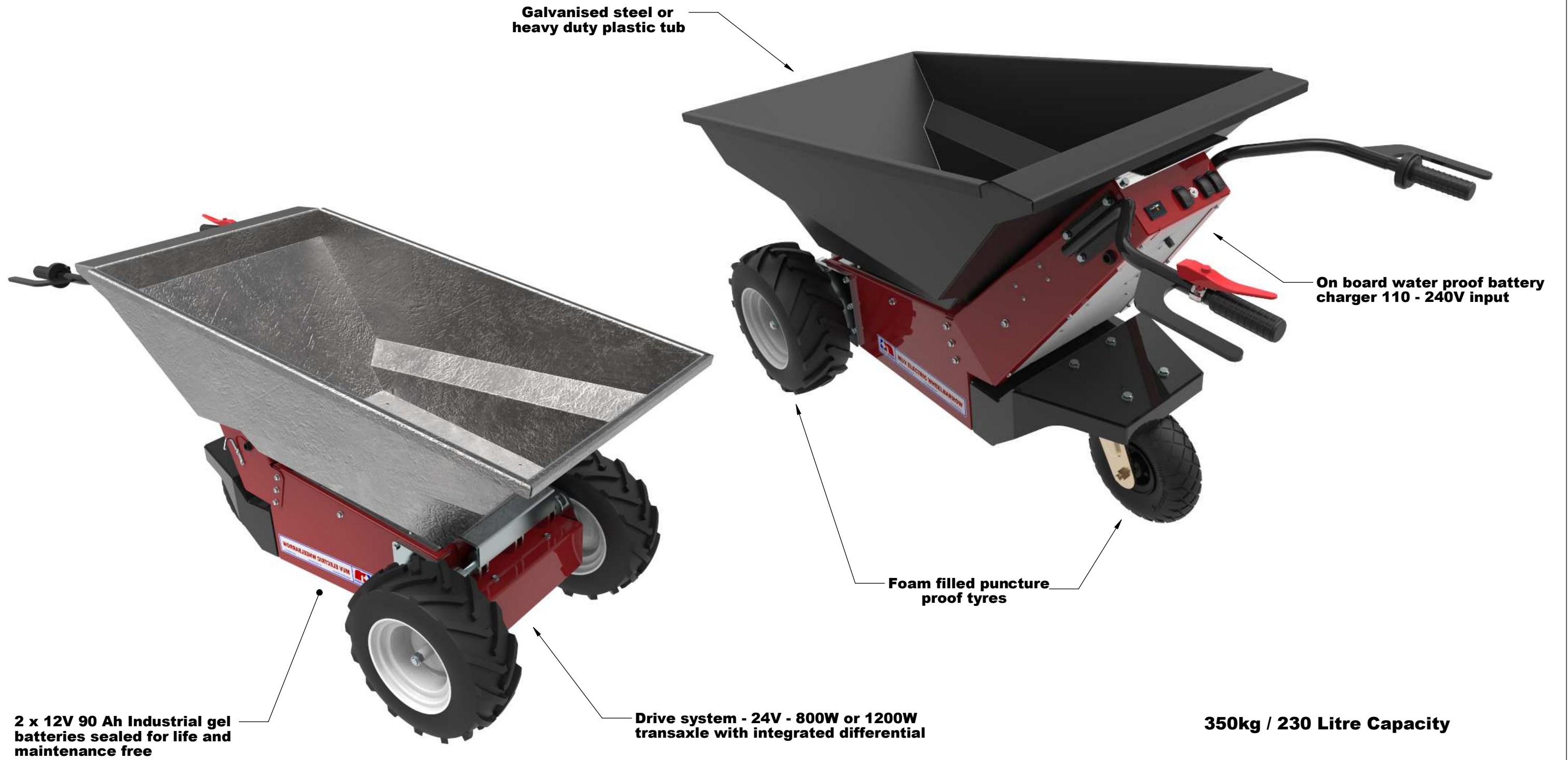

2 x 12V 90 Ah Industrial gel batteries sealed for life and maintenance free

Drive system - 24V - 800W or 1200W transaxle with integrated differential

350kg / 230 Litre Capacity

THIS DRAWING IS THE PROPRIETARY PROPERTY OF NU-STAR MATERIAL HANDLING LTD. AND MUST NOT BE USED EXCEPT IN CONNECTION WITH OUR WORK NOR IN ANY MANNER DISCLOSED TO ANY THIRD PARTY WITHOUT NU-STAR MATERIAL HANDLING LTD'S WRITTEN CONSENT. ALL RIGHTS OF DESIGN AND INVENTION ARE RESERVED.

© Nu-Star Material Handling Ltd 2002-2015

Unless otherwise specified tolerances are : .XX +/- .020 .XXX +/- .010 Angles +/- 1 deg	Finish	Date 30/01/2015
	Material	Scale

	Sheet 1 of 3	Title Overview drawing
	Issue number 1	Project MUV Electric Wheelbarrow
	Size A3	Drawing No. MUVW-221214-01

MUV Electric Wheelbarrow



Twist Grip - Cable operated throttle

Dead Mans Lever

Forward / reverse selector

Tortoise / Hare Speed Selector

Keyswitch - On / Off

Tub - Raise / Lower

Battery Gauge

THIS DRAWING IS THE PROPRIETARY PROPERTY OF NU-STAR MATERIAL HANDLING LTD AND MUST NOT BE USED EXCEPT IN CONNECTION WITH OUR WORK NOR IN ANY MANNER DISCLOSED TO ANY THIRD PARTY WITHOUT NU-STAR MATERIAL HANDLING LTD'S WRITTEN CONSENT ALL RIGHTS OF DESIGN AND INVENTION ARE RESERVED.

Unless otherwise specified tolerances are : .XX +/- .020 .XXX +/- .010 Angles +/- 1 deg	Finish	Date
	Material	Scale



Sheet 2 of 3	Title Overview drawing
Issue number 1	Project MUV Electric Wheelbarrow
Size A3	Drawing No. MUVW-221214-01

MUV Electric Wheelbarrow

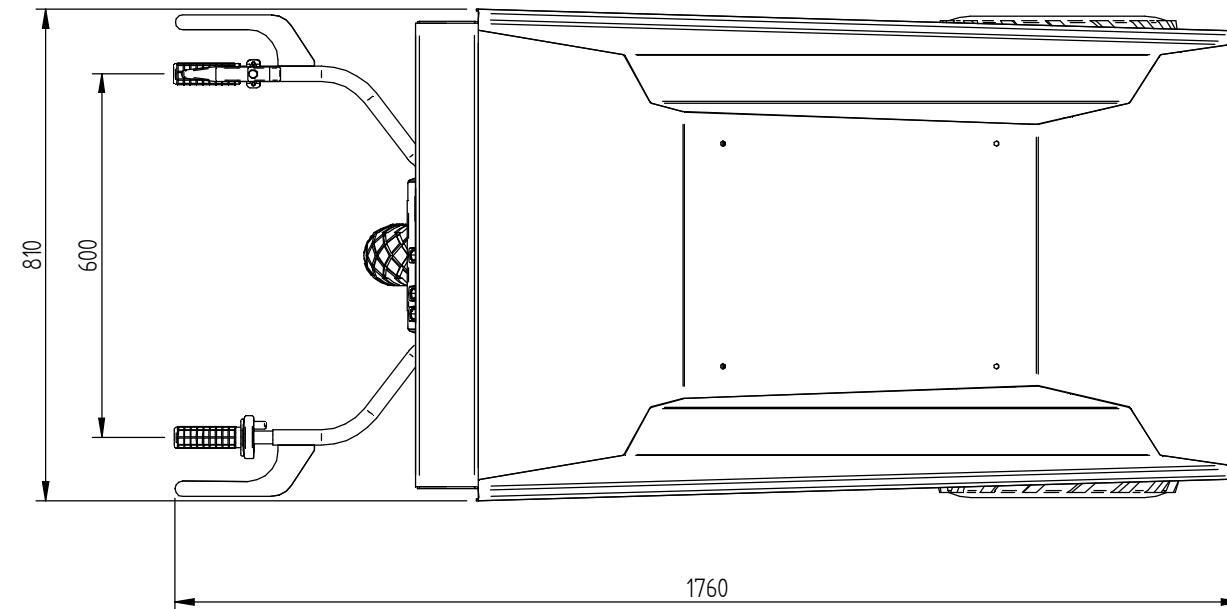
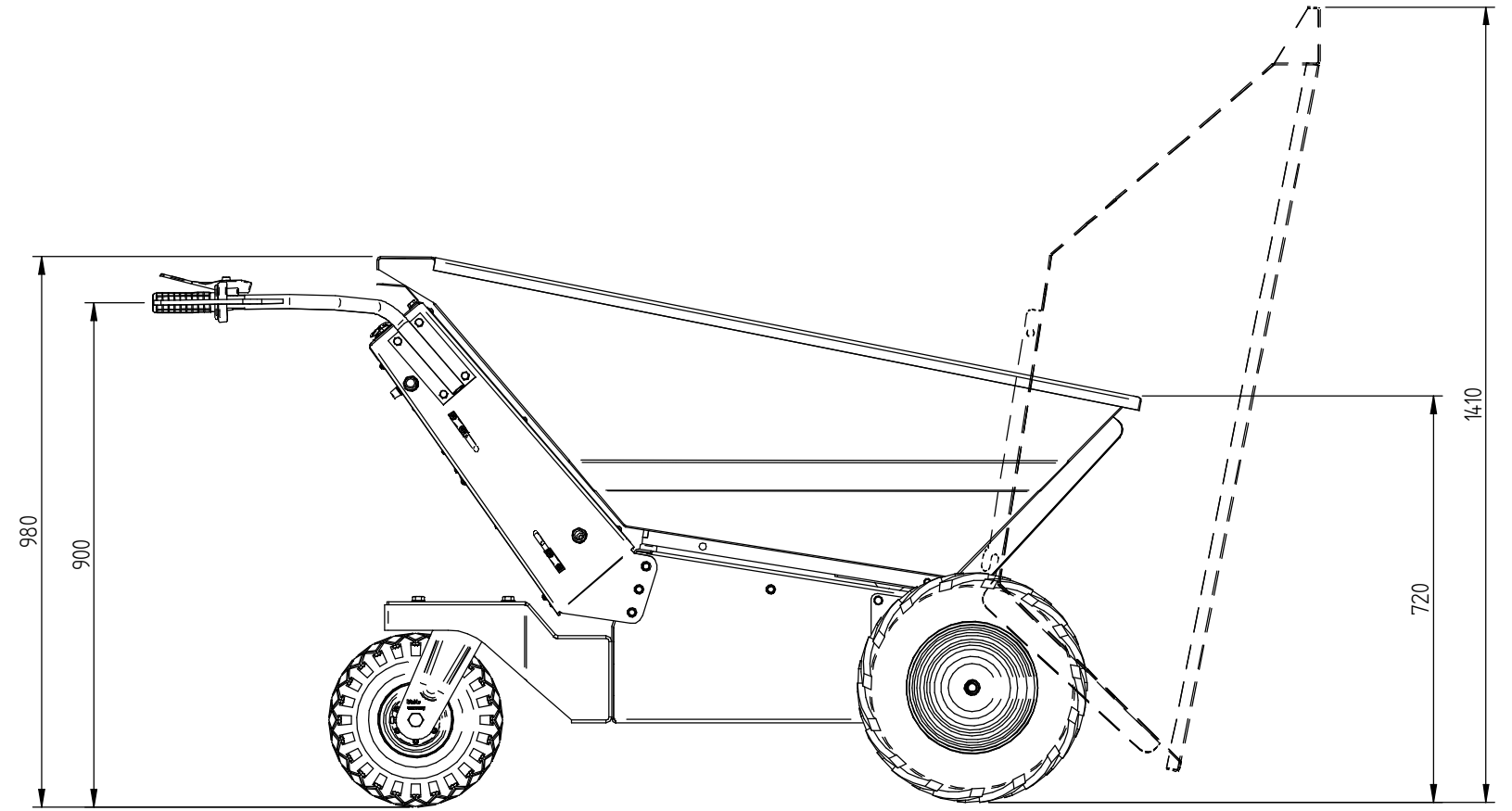
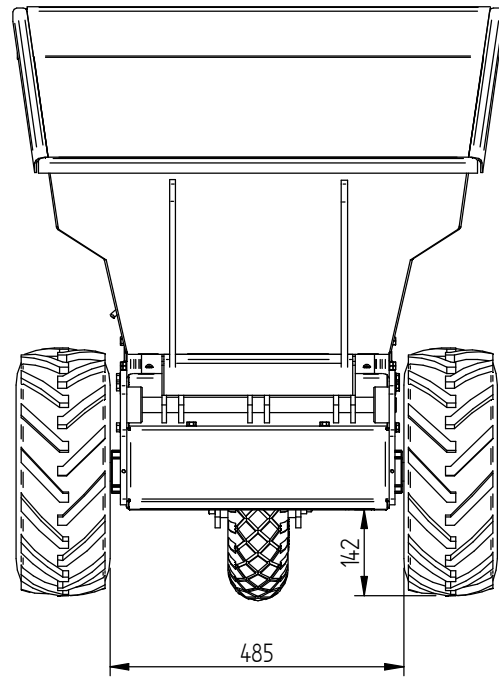

THIS DRAWING IS THE PROPRIETARY PROPERTY OF NU-STAR MATERIAL HANDLING LTD AND MUST NOT BE USED EXCEPT IN CONNECTION WITH OUR WORK NOR IN ANY MANNER DISCLOSED TO ANY THIRD PARTY WITHOUT NU-STAR MATERIAL HANDLING LTD'S WRITTEN CONSENT ALL RIGHTS OF DESIGN AND INVENTION ARE RESERVED.

© Nu-Star Material Handling Ltd 2002-2015

Unless otherwise specified tolerances are :
 .XX +/- .020
 .XXX +/- .010
 Angles +/- 1 deg

Finish	Date
Material	Scale
	30/01/2015



Sheet 3 of 3	Title Overview drawing
Issue number 1	Project MUV Electric Wheelbarrow
Size A3	Drawing No. MUVW-221214-01